

Impedance

A Combined Opposition

What you'll learn in Module 7.

Section 7.1 The Impedance Triangle.

The Impedance Triangle.

Graphical representation of Impedance.

Calculating Impedance in inductive and capacitive circuits.

Section 7.2 Impedance Matching.

Impedance matching.

The effects of input and output Impedance on amplifier gain.

Section 7.3 Measuring Impedance.

Practical methods of measuring Impedance.

Section 7.4 Impedance Quiz.

Calculations involving Impedance.

Understand the relationships between Impedance, and other AC circuit properties.

Multi stage calculations involving impedance reactance & resistance.

Measured in Ohms but NOT Resistance.

The term Impedance is familiar to anyone who has connected a loudspeaker to an audio system, it is generally a number of Ohms, often printed next to many input or output sockets. However the property of Impedance is perhaps less understood.



The word impedance is used in many engineering disciplines to refer to an opposition to work done, so this article refers specifically to electrical impedance, which describes the combined effect of resistance (R), inductive reactance (X_L) and capacitive reactance (X_C) in an AC circuit, whether it occurs in a single component, or in a whole circuit.

Because electrical impedance (here called simply "impedance") is affected by reactance (X), as well as resistance (R), it is also affected by frequency (f) and the value of impedance will change at different frequencies. Describing the impedance of a component or circuit in terms of so many Ohms is therefore inadequate (but commonly done). To be accurate, the impedance needs to be expressed as so many Ohms at a particular frequency. What frequency is used will depend on the type of circuit being described and what range of frequencies the circuit is handling. The frequency chosen for the measurement of impedance is usually around the equipment's mid frequency range. For example, in audio circuits which may have a frequency range from a few Hz to around 20kHz a frequency of 1kHz is commonly specified. Although at first this does seem like the centre of the frequency range, if this range is considered on a logarithmic scale (as frequency scales commonly are) then 1kHz is at the centre of the audio range.

Module 7.1 The Impedance Triangle

The effect of a practical (real) inductor in limiting the flow of current is not solely due to the back emf effect that gives rise to the inductive reactance X_L , but is also partly due to the internal resistance of the inductor. As these two causes, occurring in the same component, cannot be physically separated, it is often essential to consider the combined effects of both reactance and resistance on the current through the inductor. The name used to describe this combined opposition to current flow is IMPEDANCE, which is measured in OHMS but has the symbol Z .

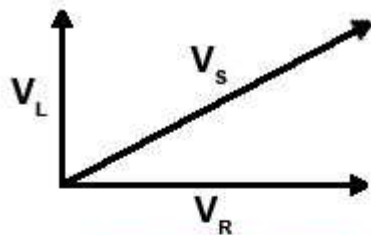

Phasor Diagram for LR Circuit

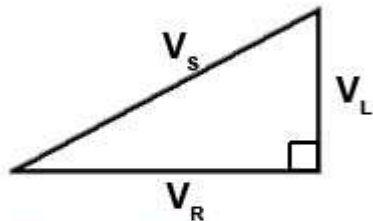

Phasors Re-drawn as a Right-angle Triangle

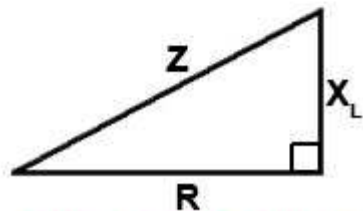

Impedance Triangle

Fig 7.1.1 Constructing an Impedance Triangle from a LR Phasor Diagram.

This combination of reactance plus resistance is not simply the sum of these quantities. To obtain the impedance of a simple series LR circuit for example, we must calculate the PHASOR SUM of the resistance and the reactance. The reason for this can be understood by studying Fig 7.1.1, which shows a phasor diagram for the circuit redrawn as a right angle triangle. The three sides of the triangle represent the three voltage phasors in the circuit V_R , V_L and V_S . Because the circuit components are in series, the same current is common to them all.

Considering the voltages V_R and V_L in Fig 7.1.1, Ohms law states that $V_R = IR$ (current multiplied by resistance), therefore V_L will equal IX_L (current multiplied by reactance)

Now, as Z is the impedance of the total circuit, the total voltage across the circuit, $V_S = IZ$

Because these phasors now form a right angle triangle, Pythagoras' theorem can be used to relate all these voltage phasors:

$$V_S^2 = V_R^2 + V_L^2$$

Therefore (Because $V = IR$ etc.)

$$(IZ)^2 = (IR)^2 + (IX_L)^2 \text{ or } I^2Z^2 = I^2R^2 + I^2X_L^2$$

Next, dividing throughout by I^2 eliminates I^2 to give $Z^2 = R^2 + X_L^2$

and taking the square root of both sides of this equation gives a formula to calculate Z (the total impedance of the LR circuit).

$$Z = \sqrt{(R^2 + X_L^2)}$$

Note: When using this formula on a calculator it is important to remember to use the brackets, or alternatively, to find the sum of $R^2 + X_L^2$ before using the square root key.

Remember that impedance, resistance and reactance are **not** phasor quantities themselves. They do affect the voltages and currents, causing these quantities to change their relationships with each other, but as Z , R and X themselves are not varying with time, they are not phasors.

Fig 7.1.2 Impedance Triangle for CR circuits.

Fig 7.1.2 illustrates the similar relationship that exists in a resistive/capacitive circuit. The voltage phasor diagram for CR circuits can be converted to a right angle triangle and treated in the same way as the LR diagrams in Fig 7.1.1 to give:

$$Z = \sqrt{R^2 + X_c^2}$$

**Fig 7.1.3 Impedance Triangle for LCR circuits.**

Fig 7.1.3 shows a further variation of the Impedance Triangle that can be used to calculate Impedance when resistance (R), Inductance (L) and Capacitance (C) are all present in the circuit, and the total reactance (X) is the difference between the Inductive Reactance (X_L) and Capacitive Reactance (X_C). In this case the formula for Z becomes:

$$Z = \sqrt{R^2 + (X_L - X_C)^2}$$

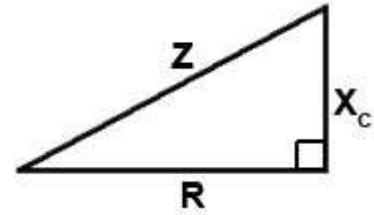
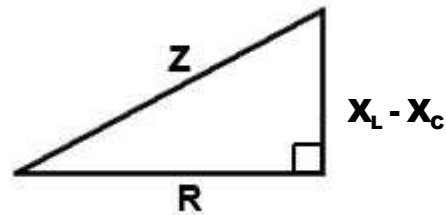

Impedance is just one of the properties that is vital to understanding AC circuits. If you have studied this module and modules 5 (Phase and Phasors) and 6 (Reactance) you should begin to see how these properties work together. To understand how impedance depends on other properties of a circuit, such as reactance and resistance, and see how impedance affects such things as current and voltage, try some calculations using the formulae from these modules in the Module 7 (Impedance Quiz).

Module 7.2 Impedance Matching.

Fig 7.2.1 Defining the Impedance Frequency.

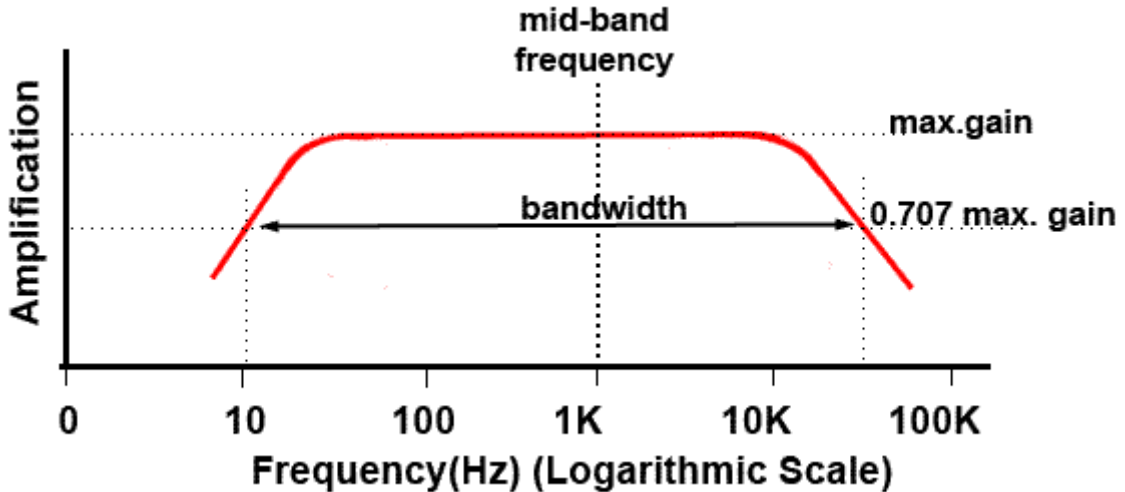

The component or circuit will not have the same impedance at all frequencies. It is common for inputs and outputs on many types of equipment to have their impedances quoted in Ohms and to assume a common frequency for that particular type of equipment. For example, audio commonly uses a frequency of 1kHz as the standard for measuring impedance. This is because 1kHz is approximately the centre of an audio amplifier's bandwidth, measured on a logarithmic scale, as shown in Fig 7.2.1. The thing to notice in equipment designed to interconnect with other units is that most inputs (to amplifiers etc) have high impedances (in Ohms) whereas outputs have much lower impedances. The reason for this is because of the effects of impedance.

Fig 7.2.2 Input and Output Impedances

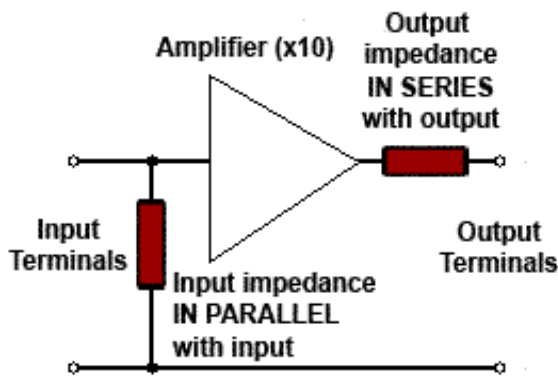

An amplifier can be considered to have two impedances that affect the way it can be connected to other amplifiers, one impedance is considered to be connected across the input terminals (because when an input source is connected to these terminals, a current flows across the terminals, therefore, there must be an impedance (shown as a resistor) for the current to flow through. At the output there is another imaginary resistor (impedance), this time connected in series with the flow of current. The effect of this output impedance is to reduce the voltage at the output terminals, and the more current drawn from the output, the more the terminal voltage is reduced, therefore there must be an (invisible) resistance across which the voltage is being dropped. The input and output impedances of an amplifier are illustrated in Fig 7.2.2

Fig. 7.2.3 Matching Input and Output Impedances.

Impedance matching of inputs and outputs is necessary because the gain of a single amplifier is often insufficient for a given purpose. For this reason several stages of amplification are used, which involves feeding the output of one amplifier into the input of another. This is called connecting the amplifiers in "Cascade". It is then important that the output impedance of the first amplifier and the input impedance of the second amplifier form a potential divider as shown in Fig 7.2.3.

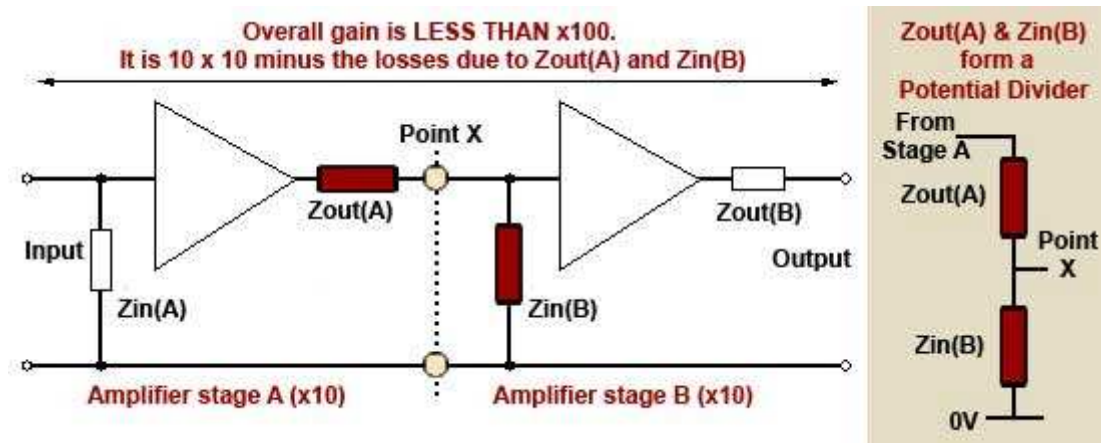

Matching Voltage Amplifiers

If the amplifiers are voltage amplifiers, i.e. amplifier stages whose voltage gain is greater than either their current or power gains, the voltage waveform needs to be coupled from one stage to the next with as little reduction in its voltage amplitude as possible. Notice that the output impedance of the first stage and the input impedance of the second stage form a potential divider, as shown in the shaded portion of Fig. 7.2.3. The voltage available at the junction of the two impedances will depend on the relative values of $Z_{in}(B)$ to $Z_{out}(A)$. The higher the value of an impedance, the more voltage will be developed across it for a given current flow. Provided that $Z_{out}(A)$ is much smaller than $Z_{in}(B)$, the majority of the available voltage at point X (the input to stage B) will be developed across its input impedance $Z_{in}(B)$, and so across stage B input terminals rather than across the first amplifier's output impedance.

Matching Power Amplifiers

In the case of power amplifiers however, as the waveform current is shared between the input and output impedances in opposite proportions to the waveform voltage, the maximum power ($V \times I$) is transferred from output to input if both impedances are equal.

The values of input and output impedance therefore have a considerable effect on the gain of multi stage amplifiers. There is always some loss of signal amplitude that occurs due to the coupling of successive amplifier stages, and in calculating the overall gain of a multi stage amplifier, the overall gain will be less than equal to the product of the individual gains of each amplifier. I.e if each stage of a two stage amplifier has a gain of 10, then the overall gain might be supposed to be $10 \times 10 = 100$; in practice however, this is not achievable due to the coupling losses incurred in matching the amplifiers, and because of even the best impedance matching, a slightly lower gain results. The value of input and output impedance can be arranged to an appropriate value by the choice of amplifier design. More complex methods of controlling impedance in multi-stage amplifiers, using negative feedback, is discussed in Amplifiers Module 3.2.

Although the above description refers to coupling amplifiers together, the same considerations apply when an amplifier is driving a power device such as a loudspeaker, a current operated device such as a motor, or in matching an input device such as a microphone to the input of a voltage amplifier.

Module 7.3 Measuring Impedance

Measuring Impedance

Because Impedance is an AC property it cannot be easily measured like resistance. Connecting an Ohmmeter across the input or output of an amplifier only indicates the DC resistance. It is quite possible however to measure input and output impedance at any frequency using a signal generator, an oscilloscope (or AC voltmeter) and a decade resistance box or a variable resistor.

Fig 7.3.1 Measuring Input Impedance

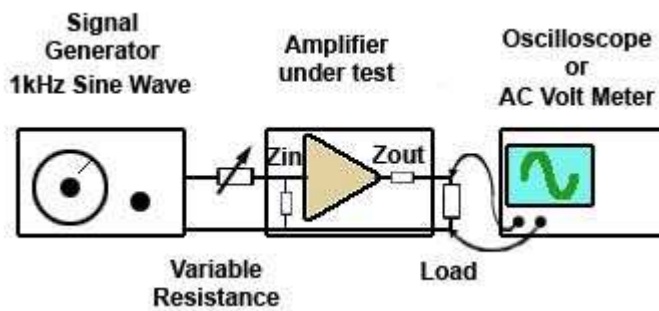

The set up for measuring input impedance is illustrated in Fig. 7.3.1. A variable resistor or decade resistance box is connected between the signal generator and the amplifier input and its resistance is set to zero Ohms. An oscilloscope or AC voltmeter is connected across the amplifier load (e.g. loudspeaker).

The signal generator is set to provide a sine wave output at 1kHz. The amplitude of the input signal should be adjusted so that the display on the oscilloscope is noise free (large enough) and distortion free (not too large). The display on the oscilloscope screen should be as large as is practical and set so that its amplitude and half its amplitude can be easily estimated.

The resistance at the amplifier input should then be increased until the output waveform is exactly half its previously set value. At this setting the signal is shared equally between the test resistance and the input impedance of the amplifier, meaning that the resistance and impedance are equal. After switching off and removing the test resistance, the reading of the decade box settings or measuring the variable resistor with an Ohmmeter gives the value equivalent to the input impedance of the amplifier.

Fig 7.3.2 Measuring Output Impedance

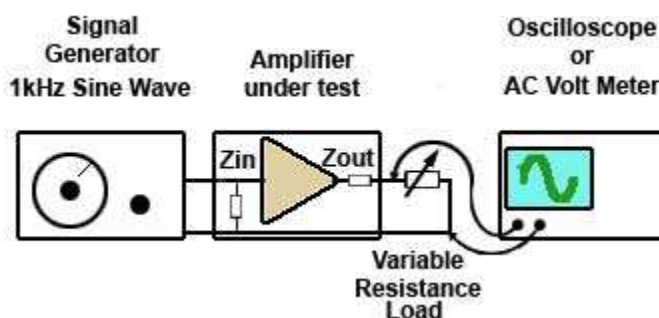

The measurement of output impedance uses the same method as for input impedance but with different connections. In this case the amplifier load is replaced with the decade box or variable resistor. Care must be taken however, to ensure that the resistance connected in place of the load is able to dissipate sufficient power without damage. The amplifier need not be run at full power for this test.

Connect the test circuit as shown in Fig. 7.3.2 and initially the output from the amplifier should be adjusted for a display similar to that used for the input impedance test, but this time with no load connected to the output terminals. The test resistance is then connected across the output terminals and adjusted for maximum resistance before switching on the amplifier. The test resistance is reduced in value until the display indicates half the amplitude of that noted with no load. The test resistance is now the same value as the output impedance.

Module 7.4 Impedance Quiz

What you should know.

After studying Module 7, you should:

Be able to carry out calculations involving Impedance.

Understand the relationships between Impedance, and other AC circuit properties.

Be able to carry out multi stage calculations involving impedance reactance & resistance.

Be able to describe practical methods of measuring input and output impedance in amplifiers.

Try our quiz, based on the information you can find in Module 7.

Note, **some questions will also require a knowledge of associated modules 5 and 6.**

Submit your answers and see how many you get right, but don't be disappointed if you get answers wrong. Just follow the hints to find the right answer and learn about Impedance as well as revising Reactance and AC Circuits as you go.

1.

With reference to Fig 7.4.1, what is the reactance X_L of inductor L?

- a) 545.25 Ω
- b) 276.47 Ω
- c) 3.67 Ω
- d) 360 Ω

2.

With reference to Fig 7.4.1, what is the Circuit Impedance Z?

- a) 545.28 Ω
- b) 221.20k Ω
- c) 61M Ω
- d) 276.52 Ω

3.

With reference to Fig 7.4.1, what is the Supply Current I_S ?

- a) 3.67mA
- b) 36 μ A
- c) 4.2mA
- d) 373mA

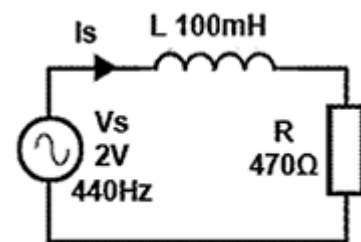

Fig 7.4.1

4.

With reference to Fig 7.4.1, what is the voltage (V_R) across the resistor R?

- a) 2V
- b) 0.54V
- c) 1.61V
- d) 1.72V

5.

With reference to Fig 7.4.2, Which of the formulae is correct for finding the value of Z in a LCR circuit?

- a) Formula a
- b) Formula b
- c) Formula c
- d) Formula d

a	b
$Z = 2\pi f/LC$	$Z = \sqrt{(X_L - X_C)^2 + R^2}$
c	d
$Z = \frac{(X_L - X_C)}{R}$	$Z = \sqrt{(R^2 + X_L^2)}$

Fig. 7.4.2

6.

With reference to Fig 7.4.3, What is the Reactance (X_C) of capacitor C?

- a) 3.39k Ω
- b) 2.95k Ω
- c) 6.28k Ω
- d) 1.54k Ω

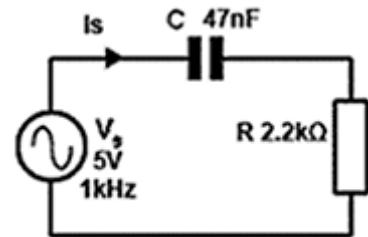

Fig. 7.4.3

7.

With reference to Fig 7.4.3, what is the Impedance (Z) of the circuit?

- a) 224.8k Ω
- b) 7.4M Ω
- c) 4.04k Ω
- d) 21k Ω

8.

When connecting two amplifiers, x and y in cascade, overall gain is reduced because the output impedance of amplifier x, and the input impedance of amplifier y... (Complete the sentence)

- a) Form a series impedance network.
- b) Contain reactance, which increases with frequency.
- c) Form a parallel impedance network.
- d) Form a potential divider.

9.

Fig 7.4.4 shows a test set-up for measuring the Z_{IN} of an audio amplifier. Which of the following should be initially connected at point X?

- a) An AC Voltmeter set to the mV range.
- b) A variable resistor set to maximum resistance.
- c) A frequency meter set to the 0 - 20kHz range.
- d) A decade resistor box set to zero resistance.

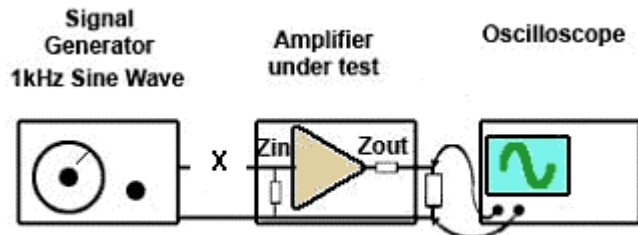

Fig. 7.4.4

10.

With reference to Fig 7.4.2, what is the Voltage (V_C) across capacitor C?

- a) 4.2V
- b) 2.5V
- c) 3.03V
- d) 4.98V