

# SN54HC352, SN74HC352 DUAL 4-LINE TO 1-LINE DATA SELECTORS/MULTIPLEXERS

D2684, DECEMBER 1982—REVISED SEPTEMBER 1987

- Inverting Versions of 'HC153
- High-Current Inverting Outputs Can Drive Up to 15 LSTTL Loads
- Permits Multiplexing from n Lines to 1 Line
- Performs Parallel-to-Serial Conversion
- Strobe (Enable) Line Provided for Cascading (N Lines to n Lines)
- Package Options Include Plastic "Small Outline" Packages, Ceramic Chip Carriers, and Standard Plastic and Ceramic 300-mil DIPs
- Dependable Texas Instruments Quality and Reliability

## description

Separate output enable inputs ( $\bar{G}$ ) are provided for each of the two four-line sections of these data selectors/multiplexers.

The SN54HC352 is characterized for operation over the full military temperature range of  $-55^{\circ}\text{C}$  to  $125^{\circ}\text{C}$ . The SN74HC352 is characterized for operation from  $-40^{\circ}\text{C}$  to  $85^{\circ}\text{C}$ .

FUNCTION TABLE

SELECT INPUTS		DATA INPUTS				OUTPUT ENABLE	OUTPUT
B	A	C0	C1	C2	C3	$\bar{G}$	Y
X	X	X	X	X	X	H	H
L	L	L	X	X	X	L	H
L	L	H	X	X	X	L	L
L	H	X	L	X	X	L	H
L	H	X	H	X	X	L	L
H	L	X	X	L	X	L	H
H	L	X	X	H	X	L	L
H	H	X	X	X	L	L	H
H	H	X	X	X	H	L	L

Select inputs A and B are common to both sections.

SN54HC352 . . . J PACKAGE  
SN74HC352 . . . DW OR N PACKAGE

(TOP VIEW)

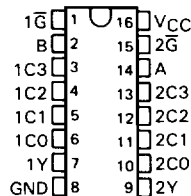

SN54HC352 . . . FK PACKAGE

(TOP VIEW)

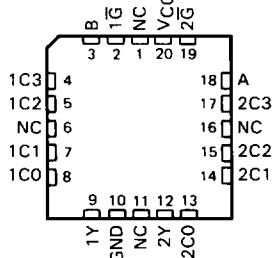

NC—No internal connection

## logic symbol†

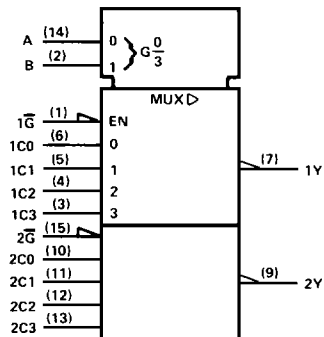

†This symbol is in accordance with ANSI/IEEE Std 91-1984 and IEC Publication 617-12. Pin numbers shown are for DW, J, and N packages.

2

HCMOS Devices

PRODUCTION DATA documents contain information current as of publication date. Products conform to specifications per the terms of Texas Instruments standard warranty. Production processing does not necessarily include testing of all parameters.

TEXAS  
INSTRUMENTS

POST OFFICE BOX 655012 • DALLAS, TEXAS 75265

Copyright © 1982, Texas Instruments Incorporated

2-383

**SN54HC352, SN74HC352**  
**DUAL 4-LINE TO 1-LINE DATA SELECTORS/MULTIPLEXERS**

logic diagram (positive logic)

**2**

**HCMOS Devices**

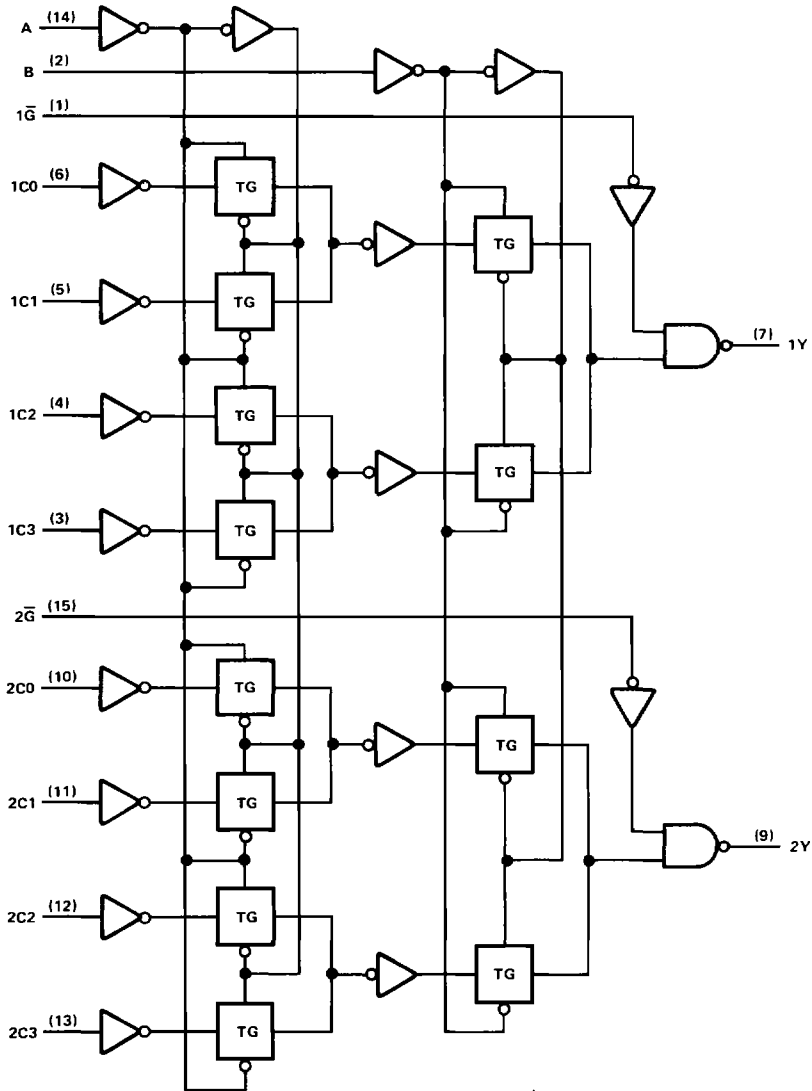

Pin numbers shown are for DW, J, and N packages.

# SN54HC352, SN74HC352 DUAL 4-LINE TO 1-LINE DATA SELECTORS/MULTIPLEXERS

## absolute maximum ratings over operating free-air temperature range†

Supply voltage, $V_{CC}$ .....	-0.5 V to 7 V
Input clamp current, $I_{IK}$ ( $V_I < 0$ or $V_I > V_{CC}$ ) .....	$\pm 20$ mA
Output clamp current, $I_{OK}$ ( $V_O < 0$ or $V_O > V_{CC}$ ) .....	$\pm 20$ mA
Continuous output current, $I_O$ ( $V_O = 0$ to $V_{CC}$ ) .....	$\pm 35$ mA
Continuous current through $V_{CC}$ or GND pins .....	$\pm 70$ mA
Lead temperature 1,6 mm (1/16 in) from case for 60 s: FK or J package .....	300°C
Lead temperature 1,6 mm (1/16 in) from case for 10 s: DW or N package .....	260°C
Storage temperature range .....	-65°C to 150°C

†Stresses beyond those listed under "absolute maximum ratings" may cause permanent damage to the device. These are stress ratings only, and functional operation of the device at these or any other conditions beyond those indicated under "recommended operating conditions" is not implied. Exposure to absolute-maximum-rated conditions for extended periods may affect device reliability.

2

HCMOS Devices

## recommended operating conditions

		SN54HC352			SN74HC352			UNIT
		MIN	NOM	MAX	MIN	NOM	MAX	
$V_{CC}$	Supply voltage	2	5	6	2	5	6	V
$V_{IH}$	High-level input voltage	$V_{CC} = 2$ V		1.5	1.5			V
		$V_{CC} = 4.5$ V		3.15	3.15			
		$V_{CC} = 6$ V		4.2	4.2			
$V_{IL}$	Low-level input voltage	$V_{CC} = 2$ V		0	0.3	0	0.3	V
		$V_{CC} = 4.5$ V		0	0.9	0	0.9	
		$V_{CC} = 6$ V		0	1.2	0	1.2	
$V_I$	Input voltage	0		$V_{CC}$	0	$V_{CC}$		V
$V_O$	Output voltage	0		$V_{CC}$	0	$V_{CC}$		V
$t_t$	Input transition (rise and fall) times	$V_{CC} = 2$ V		0	1000	0	1000	ns
		$V_{CC} = 4.5$ V		0	500	0	500	
		$V_{CC} = 6$ V		0	400	0	400	
$T_A$	Operating free-air temperature	-55	125		-40	85		°C

**SN54HC352, SN74HC352**  
**DUAL 4-LINE TO 1-LINE DATA SELECTORS/MULTIPLEXERS**

electrical characteristics over recommended operating free-air temperature range (unless otherwise noted)

PARAMETER	TEST CONDITIONS	V <sub>CC</sub>	T <sub>A</sub> = 25°C			SN54HC352		SN74HC352		UNIT
			MIN	TYP	MAX	MIN	MAX	MIN	MAX	
V <sub>OH</sub>	V <sub>I</sub> = V <sub>IH</sub> or V <sub>IL</sub> , I <sub>OH</sub> = -20 μA	2 V	1.9	1.998		1.9		1.9	V	
		4.5 V	4.4	4.499		4.4		4.4		
		6 V	5.9	5.999		5.9		5.9		
	4.5 V	3.98	4.30		3.7		3.84			
V <sub>OL</sub>	V <sub>I</sub> = V <sub>IH</sub> or V <sub>IL</sub> , I <sub>OH</sub> = -6 mA	2 V		0.002	0.1		0.1		V	
		4.5 V		0.001	0.1		0.1			
		6 V		0.001	0.1		0.1			
	4.5 V		0.17	0.26		0.4		0.33		
V <sub>OL</sub>	V <sub>I</sub> = V <sub>IH</sub> or V <sub>IL</sub> , I <sub>OL</sub> = 7.8 mA	6 V		0.15	0.26		0.4		0.33	
		6 V		0.15	0.26		0.4		0.33	
I <sub>I</sub>	V <sub>I</sub> = V <sub>CC</sub> or 0	6 V		±0.1	±100		±1000		±1000	nA
I <sub>OZ</sub>	V <sub>O</sub> = V <sub>CC</sub> or 0	6 V		±0.01	±0.5		±10		±5	μA
I <sub>CC</sub>	V <sub>I</sub> = V <sub>CC</sub> or 0, I <sub>O</sub> = 0	6 V			8		160		80	μA
C <sub>i</sub>		2 to 6 V		3	10		10		10	pF

2

HCMOS Devices

**SN54HC352, SN74HC352**  
**DUAL 4-LINE TO 1-LINE DATA SELECTORS/MULTIPLEXERS**

switching characteristics over recommended operating free-air temperature range (unless otherwise noted),  $C_L = 50$  pF (see Note 1)

PARAMETER	FROM (INPUT)	TO (OUTPUT)	V <sub>CC</sub>	T <sub>A</sub> = 25 °C			SN54HC352		SN74HC352		UNIT
				MIN	TYP	MAX	MIN	MAX	MIN	MAX	
t <sub>pd</sub>	A or B	Y	2 V	58	185	280	230	ns			
			4.5 V	17	37	56					
			6 V	14	32	48					
t <sub>pd</sub>	Data (Any C)	Y	2 V	47	175	265	220	ns			
			4.5 V	14	35	53					
			6 V	12	30	45					
t <sub>pd</sub>	G	Y	2 V	27	135	205	170	ns			
			4.5 V	10	27	41					
			6 V	8	23	35					
t <sub>t</sub>		Y	2 V	20	60	90	75	ns			
			4.5 V	8	12	18					
			6 V	6	10	15					

C <sub>pd</sub>	Power dissipation capacitance per data selector	No load, T <sub>A</sub> = 25 °C	40 pF typ
-----------------	---	---------------------------------	-----------

switching characteristics over recommended operating free-air temperature range (unless otherwise noted),  $C_L = 150$  pF (see Note 1)

PARAMETER	FROM (INPUT)	TO (OUTPUT)	V <sub>CC</sub>	T <sub>A</sub> = 25 °C			SN54HC352		SN74HC352		UNIT
				MIN	TYP	MAX	MIN	MAX	MIN	MAX	
t <sub>pd</sub>	A or B	Y	2 V	72	270	410	335	ns			
			4.5 V	22	54	82					
			6 V	19	47	70					
t <sub>pd</sub>	Data (Any C)	Y	2 V	62	260	395	325	ns			
			4.5 V	19	52	79					
			6 V	16	45	67					
t <sub>pd</sub>	G	Y	2 V	43	220	335	275	ns			
			4.5 V	14	44	67					
			6 V	12	38	57					
t <sub>t</sub>		Y	2 V	45	210	315	265	ns			
			4.5 V	17	42	63					
			6 V	13	36	53					

NOTE 1: Load circuit and voltage waveforms are shown in Section 1.

2

HC MOS Devices